

User guide

ALFRED

Courtesy announcement device
with up to 60" recordable
message

Automated attendant feature
Start/Stop interface
(SW 8.0 or better)



 **ROCOM**

Contents

Description	3
Connection diagram	6
Start/Stop interface	7
Configuration examples	8
Front panel view	11
Rear panel view	12
Features	13
Installation	14
Programming	16
Activate programming mode	16
Telephone number programming	17
Telephone number deleting	18
Answer delay programming	19
Flash signal time programming	20
Numbering plan digit number programming (automated attendant)	21
Default configuration data load	22
Message recording	23
Message recording from CD, MC or mixer	24
Play back	25
Technical data	26
Personal notes	27

Description

ALFRED is a digital announcement device with the following features:

- *Courtesy announcement*

The device must be connected to a analogue PABX extension line. This port has to be programmed on the PABX to receive, using features like call diversion or call rerouting, all calls which can not be answered by the attendant or other extensions. Depending on the required function the calls can be diverted to **ALFRED** only if the attendant or the extension is busy, doesn't answer within a specific time or in any case. With small PABX where call diversion or call rerouting features are not available the device should be programmed to receive incoming calls at the same time as the attendant. You can program then a call answer delay on **ALFRED** giving enough time to the attendant to answer the call if he/she is free. After answering the call the device can send an up to 60" long message. The message can be recorded by the user itself using the built in microphone or an external source like a CD or MC player. At the end of the message the device will send a flash signal, followed by an up to 16 digit long telephone number. This will connect the answered call back to the attendant, or other extension. Now the external call will be placed in the waiting queue of the PABX. Using an optional MOH device like the **Phonphon**, the waiting caller can now receive waiting messages with a background music. The external music on hold source can be also connected to **ALFRED** and then forwarded to the PABX MOH input as well. In this case you will have a courtesy announcement system with the same background music for all the duration of the process.

- *Automated attendant*

This feature can be activated by programming. With this feature activated the caller party can be invited, during the greeting message, to dial a specific internal number using his DTMF dial pad. If the caller will follow the instruction, the device will stop the outgoing message as soon as a valid DTMF digit is detected. At the end of the dial **ALFRED** will transfer the call to the dialed number and not to the stored one. The device will not survey the dialed number. Only the number length is programmed in the device. This gives a high grade

of flexibility in the possible applications of this feature. To ensure that the external caller may not activate PABX features or external calls, the extension line with the connected **ALFRED** should be restricted using the class of service programming of the PABX.

If the caller doesn't dial a number, or if the dialed number is shorter than the programmed length, the device will forward the call to the programmed extension at the end of the message or after a time out.

- Digital announcement device

If no telephone number is programmed, the device will work as a digital announcement device. After the message the connection will be released.

- Digital announcement device with start/stop interface

The device has a built-in start/stop interface. This interface can be used to connect **ALFRED** to larger PABX with this specific interface (like Siemens Hicom 300 or Nortel) or ACD systems. With this interface the unit can be used also as digital announcement device for other kind of installations (i.e. PA systems). The start/stop interface has a start input (5 to 48Vdc), a busy signal output and an isolated LF signal output. Both start/stop and t/r interface can be used at the same time, as far as for both of them the same message is used.

- Modular expandable

Up to four units can be configured together as one device. One of the units is automatically identified as master unit. All the programming and the recording of the message is done on the master unit. This unit will then forward automatically the information and messages to the connected devices. In this way you can configure a multiline device with the same message for all channels. After the recording and programming all units will work stand alone for the normal business.

The following programmations can be done on the **ALFRED**:

- 1 to 16 digits long telephone number (0 bis 9, *,#)

- Delay on answer (0 to 99 calls)
- Flash signal duration (0 to 999 ms)
- Internal numbering plan length (1 to 16 digits)

The programming is done using DTMF dial signals. For this procedure **ALFRED** has to be called, after the programming mode has been activated. After the answer you will receive a acknowledge tone and the programming can be done using a DTMF dial pad. Follow the instructions on the following pages.

The message is stored on a EEPROM memory using the DAST procedure. This memory is protected against loss of data due to power failure for a period of ten years. The message can be recorded using the build-in microphone or an external source.

The message volume can be regulated. The output impedance is about 600 Ohm. The power supply is provided by the attached plug PSU.

Connection diagram

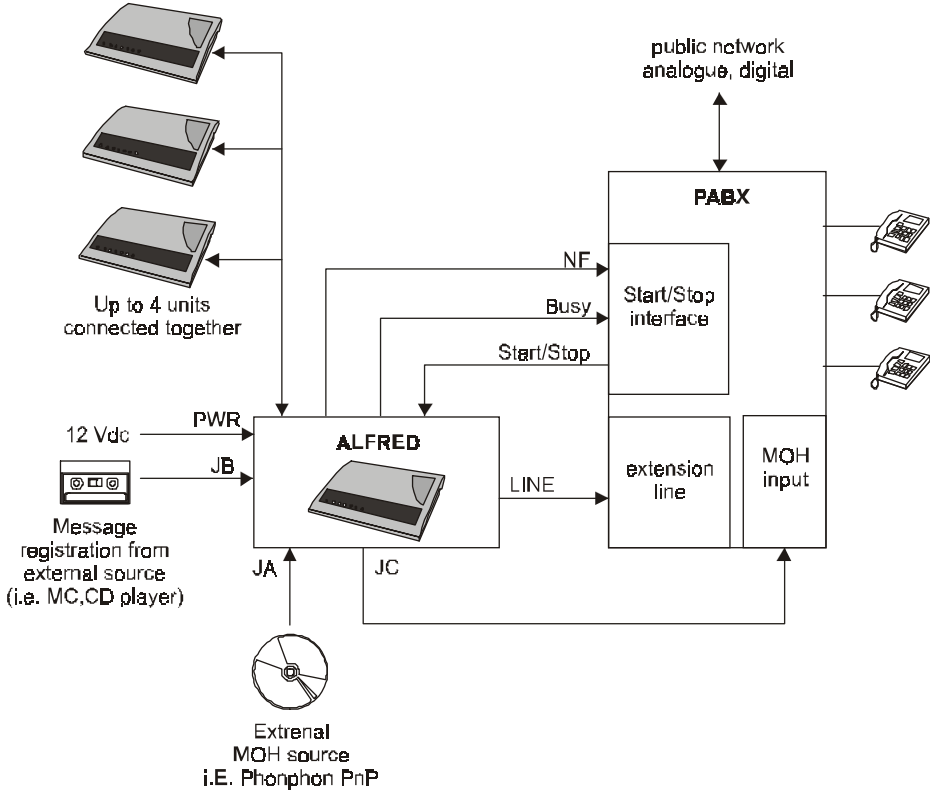

Start/Stop interface

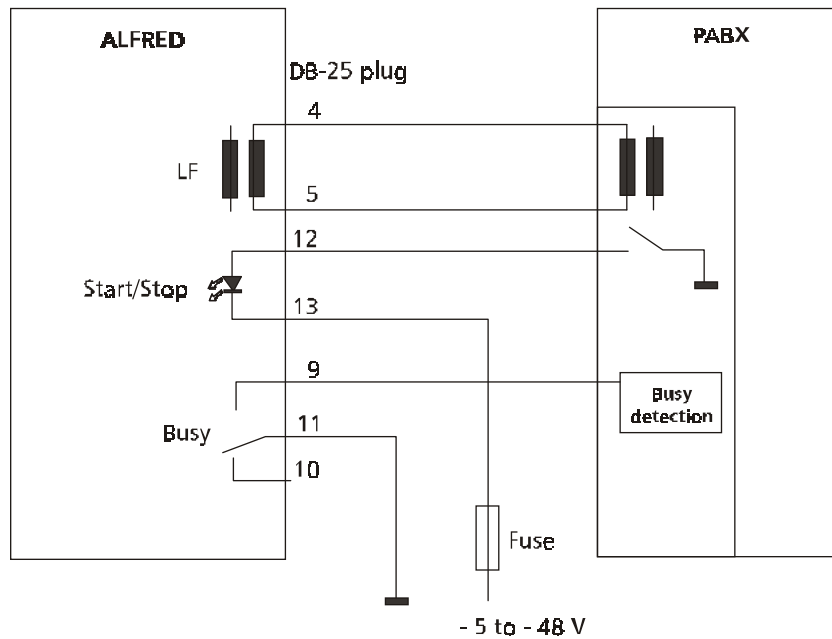

The start/stop interface is used to connect **ALFRED** to larger PABX (like Siemens, Nortel or Alcatel). Over this interface the PABX can control the the stored message and synchronise itself with the lenght of it. Applying a DC voltage between 5 and 48 V on the pins 12 and 13 of the DB 25 connector the message will be started. At the same time the busy relais contact on the pins 11 and 9 will be closed (opened on the pins 11 and 10). At the end of the stored message the busy contact will be opened (closed) again. With the busy contact the PABX can determine the aviability of the device for a new call. The message is send on a 600 ohm galvanic isolated output (LF signal output on pins 4 and 4 of the DB 25 connector). The device is delivered with a DB 25 plug. The connection cable to the PABX has to be prepared on the installation site.

Configuration examples

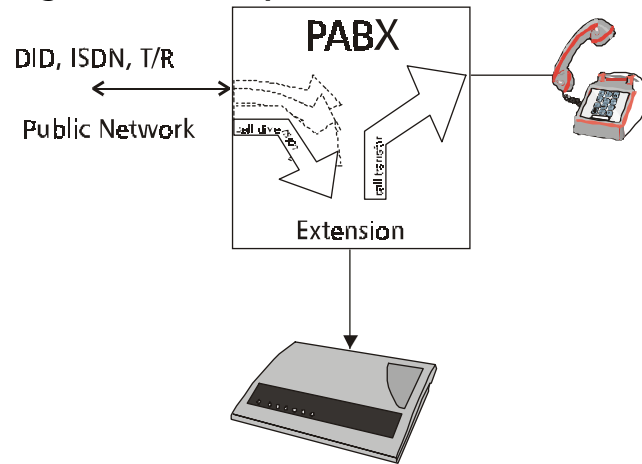

Example 1. Courtesy announcement with busy attendant

- Call diversion on busy feature is activated for the attendant.
- If the attendant is busy the call is diverted immediately to **ALFRED**.

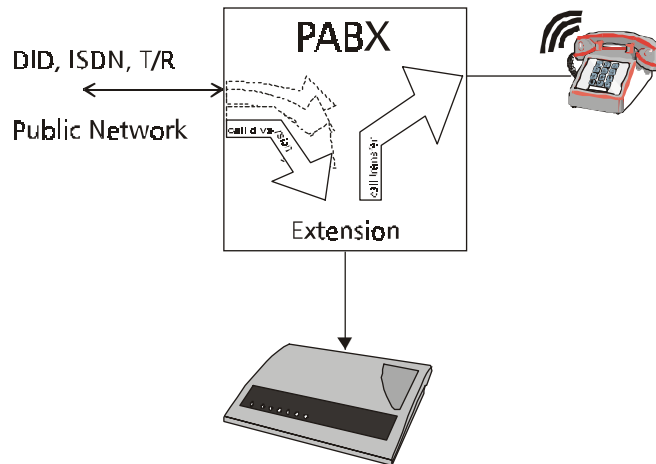

Example 2. Courtesy announcement with no answer

- Call diversion after time is programmed for the attendant/extension.
- The call is forwarded to **ALFRED** only if the attendant/extension doesn't answer.

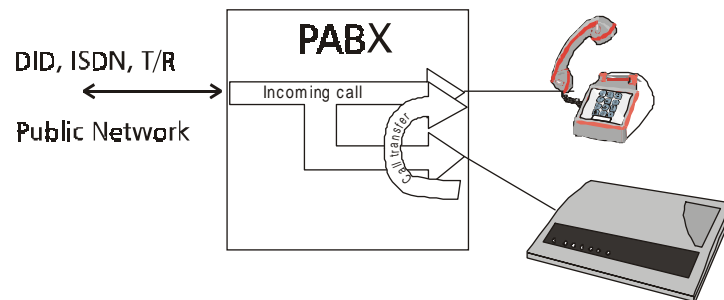

Example 3. Courtesy announcement with no answer or busy attendant

- Attendant and **ALFRED** are called at the same time.
- The call will be answered by **ALFRED** only after a programmed delay.

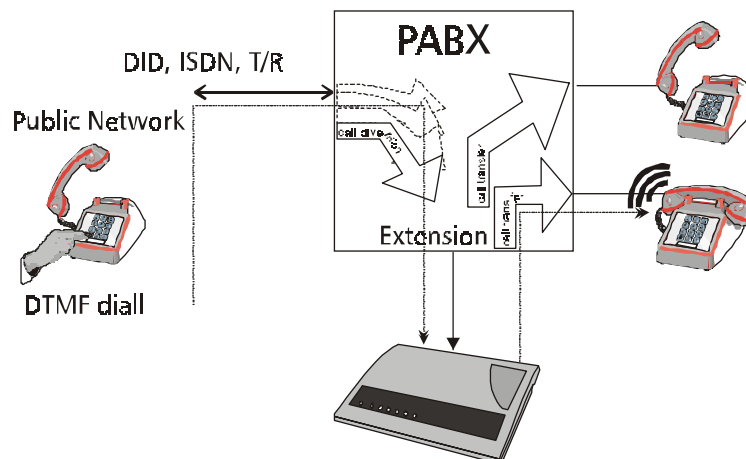

Example 4. Courtesy announcement with busy operator and automated attendant

- Call diversion on busy feature is activated for the attendant.
- If the attendant is busy the call is diverted immediately to **ALFRED**.
- The waiting caller can dial during the message an internal number using the DTMF dialpad.

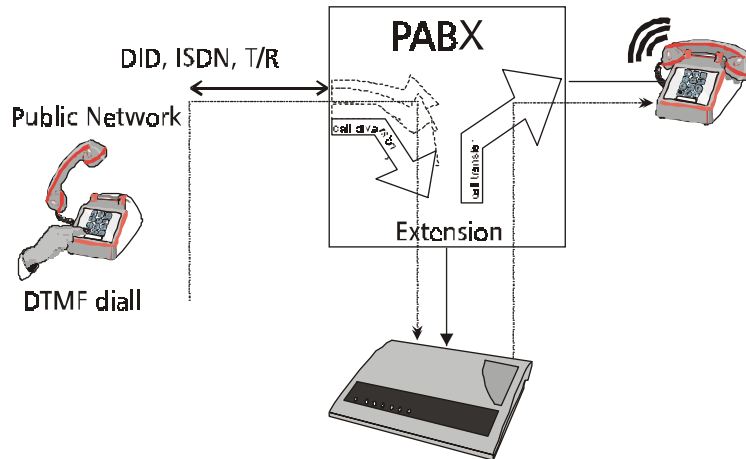

Example 5. Automated attendant

- Alfred is programmed to receive all incoming calls.
- The caller can dial during the message an internal number using the DTMF dialpad.
- If no number is dialed the caller will be connected to the attendant.

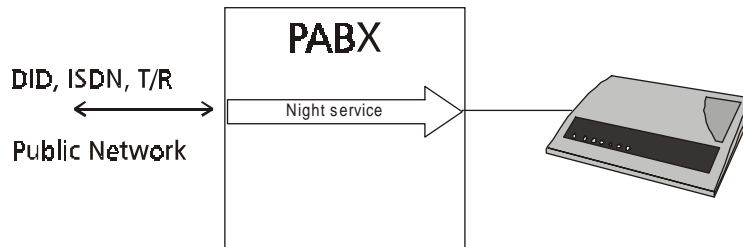

Example 6. Night message

- Alfred is programmed as night answer machine.
- The call will be answered immediately. At the end of the message the connection will be released.

Front panel view

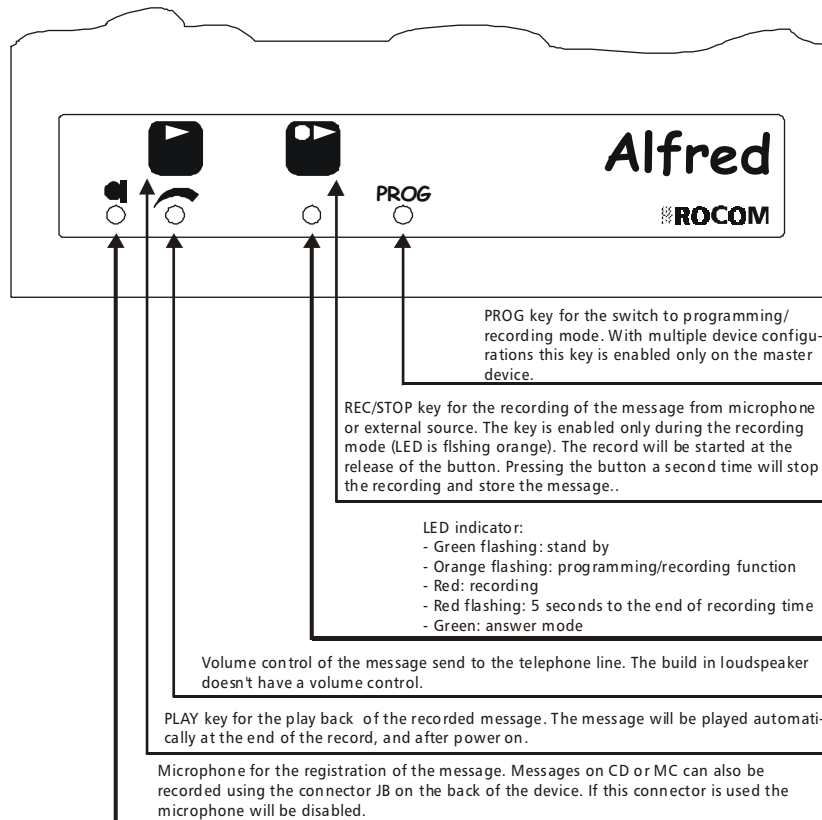

Rear panel view

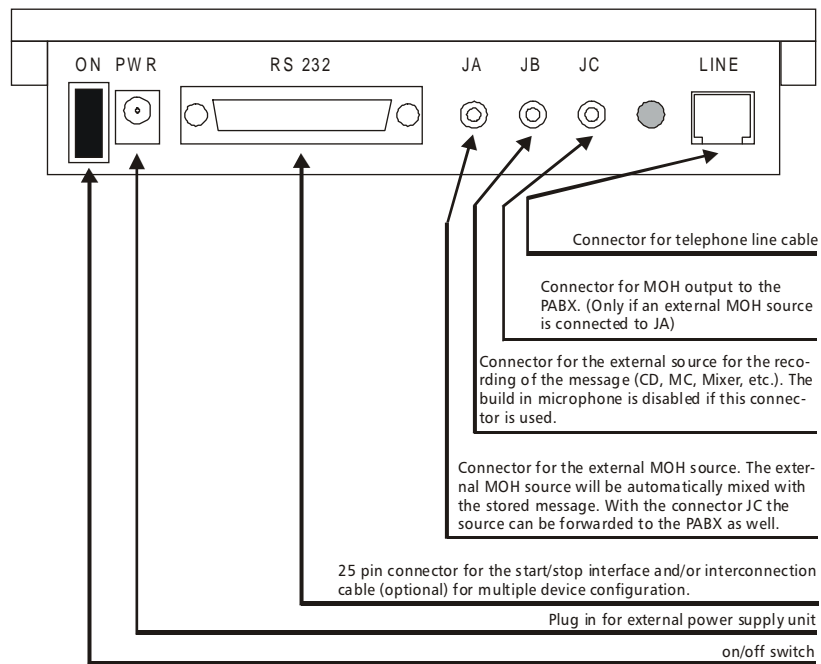

Features

- On site recordable message
- Build in microphone for on site message recording
- Build in loudspeaker for the play back of the recorded message
- Input for external source (i.e. CD, MC or mixer) to record the message
- Courtesy announcement service for quite any type of trunk and PABX
- Up to 16 digits long programmable telephone number
- DTMF dial
- Programmable flash signal time from 0 to 999 ms
- Programmable answer delay from 0 to 99 rings
- Message output level control
- Up to 60 seconds recordable message length
- Programmation using DTMF dial
- Automated attendant feature (DTMF dial in during message)
- Multiple device configuration with one master and up to three slave units
- Build in start/stop interface with busy signal
- 230 Vac power supply with external unit
- Small case
- Nice shaped case
- Fast and easy installation and programmation

Installation

The installation place of the device should be:

- in a dry room;
- far from dirt, heat and direct sun light;
- far from device generating strong electromagnetic fields (like loudspeaker);
- far from liquids and chemical aggressive substances.

Before you start with the installation please note:

- The device can be powered only with voltage indicated on the identification label.
- The device doesn't contain maintainable parts and should be opened only by instructed technicians.
- If a liquid should get into the device disconnect immediately the power supply. The device should be opened only by instructed technicians.
- To polish the device use only a clean and soft cloth. To remove spots use a humid cloth or a natural cleaning substance. Do not use chemical substances or petrol, these might damage the plastic of the case.
- Do not drop or shock the device.
- Static discharge may damage the device. Ensure that you discharge yourself using an appropriate grounding before handling the unit.

Installation

- Connect the device to a telephone plug using the line cable. The PABX must be programmed to work together with the device. This procedure is different from PABX to PABX. For the normal use the extension line with the connected **ALFRED** should be programmed to receive incoming calls at the same time as the attendant during day service. Other type of programmations can use the call diversion features of the PABX. For a best service the PABX should have the feature "call waiting on busy extension", where an external call can be put on a waiting queue for a busy extension by a call transfer.
- If a multiple device configuration has to be installed the units are to

be connected together. The connection cable has to be ordered separately (Rocom part no. 10-5000-0010). The cable is provided for the connection of four units. The master unit is identified automatically by plugging in the master connector. All other devices are identified as slave units.

- If an external music source has to be connected (i.e. CD-Player, or Rocom Phonphon MOH Player part no. 10-1200-0000) the plug JA has to be used. The external music can be forwarded to the PABX using the plug JC and the provided cable. After the connection of an external music source the volume of it may be regulated for a correct working together with the **ALFRED** device.
- To use the start/stop interface a special cable has to be made on site. Use the provided DB 25 plug. Refer to the schematics shown on page 7. For a multiple device configuration with start/stop interface, an optional interconnect cable (Rocom part no. 10-5000-0020) has to be ordered.
- Connect the provided power plug to the device and into the mains plug. Switch the unit on.
- After the play back of the stored message the device is ready to work. Therefore it has to be programmed first. To program the unit press the button PROG. The orange LED will flash fast. Call now the unit using a phone with DTMF dial pad. If you don't call the unit within 30 seconds, it will automatically switch back to the stand by mode (green LED slow flashing). In programming mode also the message can be recorded using the built in microphone or an external source. For the programming of the device and the recording of the message please read the following instructions.

Programming

Activate programming mode

To activate the programming mode press, using a pen or a small screwdriver the PROG button. The orange LED will flash fast.

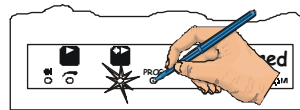

Using a phone with enabled DTMF dial pad call the device using the internal telephone number of the extension line where the unit is connected to. The device will answer the call the send three short tones. The LED will be switched off as soon as the first DTMF digit is recognized. After this the green LED will go shortly on with any received DTMF digit. After pressing the PROG button you will have about 30 seconds to call the device or to start with the recording of the message. If this will not happen the device will go back to stand by mode automatically (green LED flashing slow). In programming mode you might hear the following tones:



- Input is correct: three tones
- Input is wrong: six tones
- Error in the device: nine tones

The programming mode will be terminated dialing the digit 3, or automatically with no action within 30 seconds, or switching the unit off and on. With a multiple device configuration the programming and recording is done only on the master unit. This will then forward the information and message to the connected slave devices.

Telephone number programming

The herewith programmed telephone number will be dialed at the end of the message after sending a flash signal. At the end of the dial the device will release the line. If no number is stored the unit will work as an answering machine. At the end of the message the line will be released without dial.

Activate the programming mode. See also page 16.

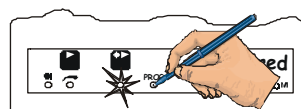

Call the device using a telephone with DTMF dial pad.

You hear three short tones.

Dial now: * # 1

You hear three short tones.

Dial now the desired telephone number, max. 16 digits long. The DTMF digits * and # can be used also as part of the telephone number, but only as first digit and only once.



Dial at the end of the telephone number: * *

You hear three short tones.

The telephone number is stored.

You can now go ahead to program the following steps or terminate the programming dial the digit 3.

PLEASE NOTE!

Some PABX can detect automatically if the telephone has a rotary dial or DTMF dial pad. The dial mode can be detected only if the dial is started without a flash signal. To ensure that with an Alfred connected to such a PABX the dial mode can be detected correctly the device will send the stored number without flash every time it will be switched on. At the first activation you should program the number and then switch the device off and on. This will ensure that the correct dial mode is setup at the PABX and you can check the correct stored number.

Telephone number deleting

Without a programmed telephone number the device will work as an answer machine. At the end of the message the line will be released. **This is the default configuration of the device.**

Activate the programming mode. See also page 16.

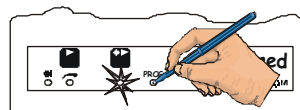

Call the device using a telephone with DTMF dial pad.

You here three short tones.

Dial now: * # 6

You here three short tones.

The telephone number is deleted.

You can now go ahead to program the following steps or terminate the programming dial the digit 3.



Answer delay programming

The device will wait for the programmed number of calls before answering. The default configuration is 00 calls: no delay.

Activate the programming mode. See also page 16.

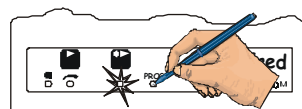

Call the device using a telephone with DTMF dial pad.

You here three short tones.

Dial now: * # 2

You here three short tones.

Dial now the number of rings 00 to 99 to be waited before answering the call. Insert the value always with two digits!

You here three short tones.

The answer delay is programmed.

You can now go ahead to program the following steps or terminate the programming dial the digit 3.



Flash signal time programming

Here you can program the flash signal (recall button) time for the connected PABX. A recall activation with ground button is not possible. **The default configuration is 80 ms.**

Activate the programming mode. See also page 16.

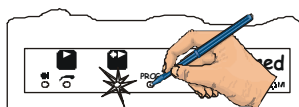

Call the device using a telephone with DTMF dial pad.

You here three short tones.

Dial now: * # 3

You here three short tones.

Dial now the flash signal time in milliseconds **000 to 999**. Insert the value always with three digits!



You here three short tones.

The flash signal time is programmed.

You can now go ahead to program the following steps or terminate the programming dial the digit **3**.

Numbering plan digit number programming (automated attendant)

This programming will activate the automated attendant feature. With this feature the waiting party can be invited to dial a DTMF number during the waiting message. If this will happen the device will wait until the here programmed number of digits are dialed by the calling party. After this it will terminate the message and forward the call to the dialed number. The device will NOT take any control of the dialed number. If no number is dialed the unit will forward the call to the programmed number. **The default configuration is 00: no automated attendant feature.**

Activate the programming mode. See also page 16.



Call the device using a telephone with DTMF dial pad.

You here three short tones.

Dial now: * # 4

You here three short tones.

Dial now the desired number of digits required by the numbering plan of the PABX from **00** to **16**. Insert the value always with two digits!



You here three short tones.

The numbering plan digit number is programmed.

You can now go ahead to program the following steps or terminate the programming dial the digit **3**.

Default configuration data load

With this function you can reload the default configuration data as indicated.

Activate the programming mode. See also page 16.

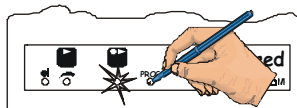

Call the device using a telephone with DTMF dial pad.

You here three short tones.

Dial now: * # 999

You here three short tones.

The default configuration data are loaded. Only the programmed number will be maintained.

You can now go ahead to program the following steps or terminate the programming dial the digit 3.



Message recording

Activate the programming mode. See also page 16.

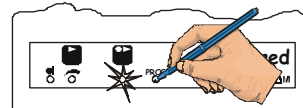

Press the REC/STOP button. The record will start as soon you release the button. The red LED will light.

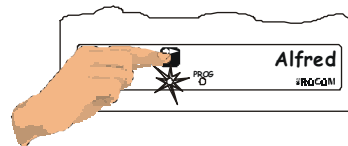

Speak your message as close as possible into the microphone. The record length is about 60 seconds. As the red LED will start flashing, you will have 5 seconds of recording time left.

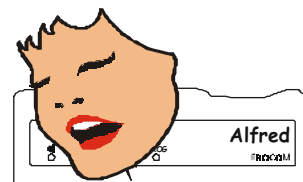

At the end of the recording time, or if you press the START/REC button again, the device will switch to play back mode and you can hear the recorded message on the internal loudspeaker. The green LED will light during the play back. At the end of the message the unit will go in stand by mode. The green LED will flash slowly.

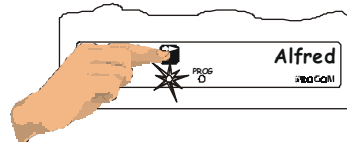

You can hear to the recorded message all time pressing the PLAY button. During the play back the green LED will light.

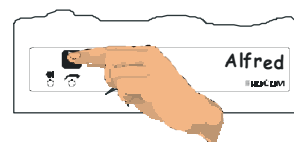

Message recording from CD, MC or mixer

Connect the external source to the JB plug on the back of the device.

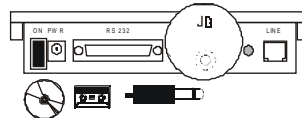

Activate the programming mode. See also page 16.

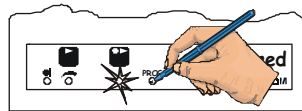

Press the REC/STOP button. The record will start as soon you release the button. The red LED will light.

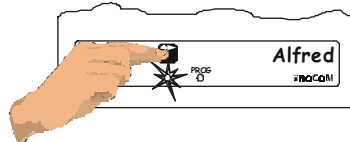

Start the message paly back on the external device. The record lenght is about 60 seconds. As the red LED will start flashing, you will have 5 secondes of recording left.

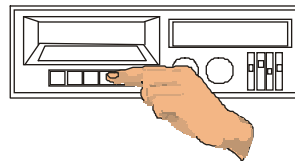

At the end of the recording time, or if you press the START/REC button again, the device will switch to play back mode and you can hear the recorded message on the internal loadspeaker. The green LED will light during the play back. At the end of the message the unit will go in stand by mode. The green LED will flash slowly.

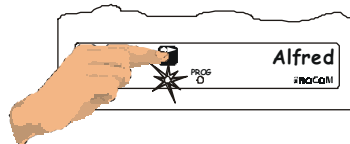

You can hear to the recorded message all time pressing the PLAY button. During the play back the green LED will light.

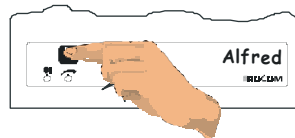

Play back

You can hear to the recorded message all time pressing the PLAY button. During the play back the green LED will light.



After recording the message to your satisfaction you can connect the device to the PABX. For any question about this matter refer to your technical support for the PABX. After the connection and programming of the PABX test the installation calling the PABX and waiting until ALFRED will answer the call.

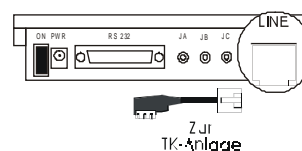

With a small screwdriver you can now regulate the volume of the message level on the telephone line. If the message will still be too low, you should record the message again using a higher output level on the external device or getting closer to the microphone

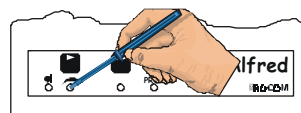

Technical data

DESCRIPTION

Dimensions	140 x 180 x 38 mm (D,L,H)
Weight	max. 400 g
Power supply	12 Vdc; max. 400 mA
Power supply unit	230 Vac +6 /-10%; 50 Hz;
Signal output level	max. -10,5 dB, regulated
Output impedance	600 Ohm
Bandwith	300 bis 3400 Hz
Digitalisation	DAST, 8 kHz scanning frequency
Memory	EEPROM, 10 years data retain
Message lenght	60 seconds
No. of messages	1
Enviroment	0° to +45°C; max. 90% umidity
Electical security	EN 60950
Class of protection	IP 30 DIN 40050
Electromagnetical immunity	EN 60555-2, EN 55022, EN 50082-1

Personal notes

© 2001 ROCOM GmbH. Product may change without notice. We do not respond for any errors or mistake in the present documentation.
Printed in Germany.

Your dealer:

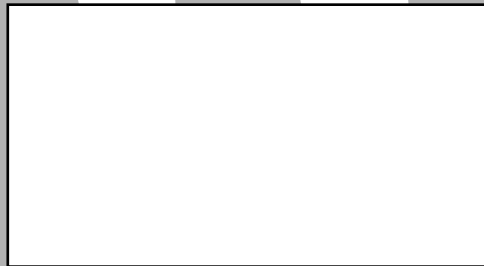

Manufactured by:

 **ROCOM**

Energie- und Kommunikationssysteme GmbH
Lessing Str. 20, 63110 Rodgau, Germany
Tel. +49-6106-6600-0 Fax +49-6106-6600-66
E-Mail: rocom_gmbH@t-online.de
<http://www.rocom-gmbh.de>