

**D** FTDUO Kurzbedienungsanleitung

**GB** FTDUO quick guide

**I** FTDUO guida rapida

## Audio

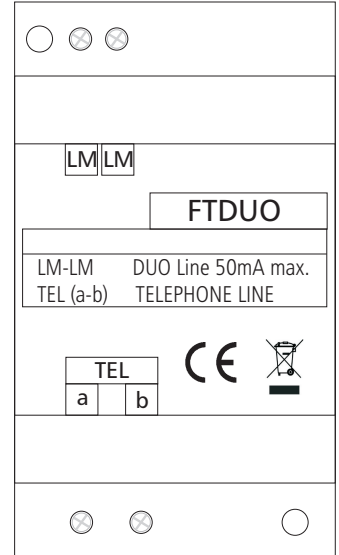
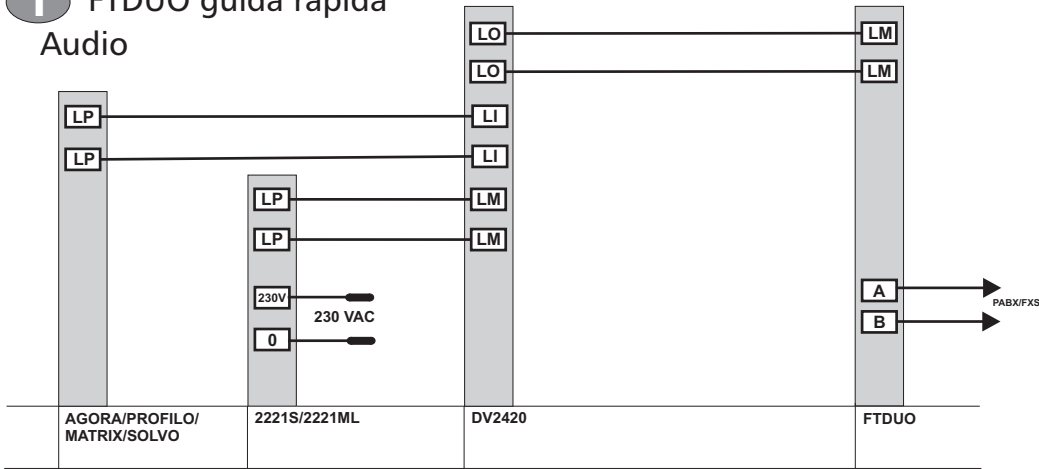

## Audio/Video

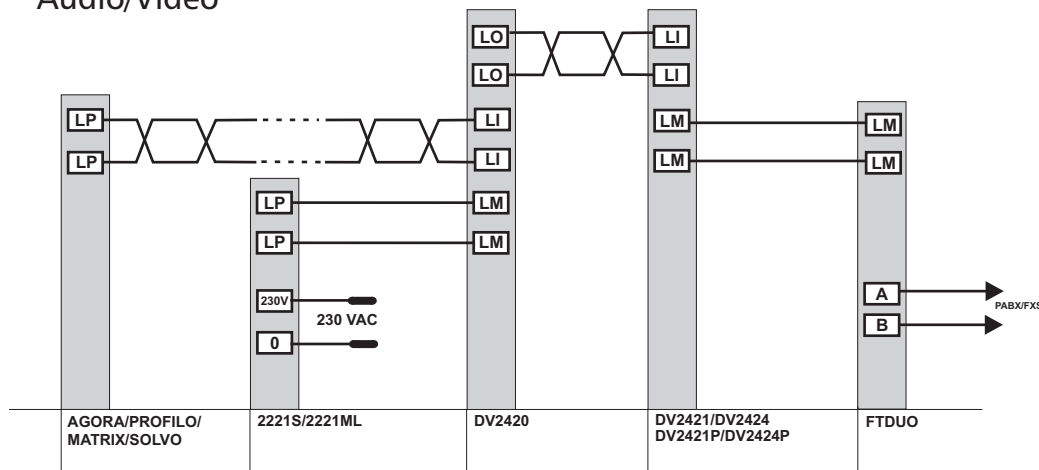

**D** FTDUO Programmierung

**GB** FTDUO programming

**I** FTDUO programmazione

### Programmierung starten / Activating programming mode / Attivazione modalità di programmazione

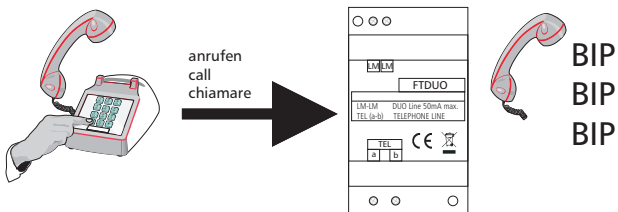

### Grunddaten laden / Load default data / Carica dati di fabbrica



**Manuelle oder automatische Anrufbeantwortung / Manual or automatic call answer / Riposta manuale o automatica (Default: manuell/manual/manuale)**

8 8 8 7 5 1 - 4 0 - 1

Taste (nur bei Betriebsart "Standard, ansonsten immer "1")  
 Button (only with "Standard" mode, otherwise always "1")  
 Tasto (solo in modalità "Standard", altrimenti sempre "1")

0 = automatische, 1 = manuelle  
 0 = automatic, 1 = manual  
 0 = automatica, 1 = manuale

**Betriebsart als Master oder Slave/ Master or slave function / Funzione in modalità master o slave (Default: slave)**

8 8 8 7 6 1 - 4 0 - \*

Taste (nur bei Betriebsart "Standard, ansonsten immer "1")  
 Button (only with "Standard" mode, otherwise always "1")  
 Tasto (solo in modalità "Standard", altrimenti sempre "1")

0 = Master, \* = Slave (Gerät wird parallel zu einem HT (Master) betrieben)  
 0 = Master, \* = Slave (Device is connected in parallel to a intercom (Master) unit)  
 0 = Master, \* = Slave (Dispositivo collegato in parallelo con un citofono (Master))

**Betriebsart "Standard" (max. 4 Tasten) oder "Erweitert" (bis zu 80 Tasten) / "Standard" (max. 4 buttons) or "expanded" (up to 80 buttons) mode / Modalità "Standard" (max. 4 tasti) o "estesa" (fino a 80 tasti) (Default: "Standard")**

8 8 8 7 8 1 6 - 7

6 = Standard, 7 = Erweitert  
 6 = Standard, 7 = Expanded  
 6 = Standard, 7 = Estesa

**Klingeltastenadressen (Standard) / Chime buttons address (Standard) / Indirizzi pulsanti di chiamata (Standard) (Default: 100)**

8 8 8 7 4 1 - 4 0 0 1 - 2 0 0

Taste  
 Button  
 Tasto

Adresse der Taste in der Türstation  
 Address of the button in the door station  
 Indirizzo del tasto nella pulsantiera

Erste Klingeltastenadresse (Erweitert) / First chime buttons address (Expanded) / Primo indirizzo pulsanti di chiamata (Estesa)



8 8 8 7 4 1 0 0 1 - 1 2 1



Adresse der ersten Taste in der Türstation  
Address of the first button in the door station  
Indirizzo del primo tasto nella pulsantiera



**D** Je nach Betriebsart ist die Verwaltung der Zuordnung der Klingeltastenadresse zu den jeweiligen "Tasten" im Adapter unterschiedlich. Als "Taste" werden keine echte Tasten sondern die eigentlichen Rufnummerspeicherplätze im Adapter definiert. Diese müssen zu den entsprechenden Adresse der Klingeltasten in der Türstation zugeordnet werden. Die Adressen der Klingeltasten werden in der Türstation festgelegt (siehe hierzu die entsprechende Bedienungsanleitung). Mit "Standard" müssen die Klingeltastenadressen (von 001 bis 200) den einzelnen "Tasten" (1 bis 4) zugeordnet werden. Mit "Erweitert" wird nur die erste Klingeltastenadresse (001 bis 121) festgelegt. Die "Tasten" (10 bis 79) erhalten dann sequentiell die entsprechenden Klingeltastenadressenzuordnung.

**GB** Depending from the selected operational mode the association of the bell button address to the "button" inside the adapter is different. We define as "button" not a true button but a store place for the telephone number inside the device. Those must be associated to the address of the bell button in the door station. This address are defined in the door station (read here the specific user guides for more information). In "Standard" mode the bell button address (from 001 to 200) must be associated to the single buttons (1 to 4). In "Expanded" mode only the first button address (from 001 to 121) must be programmed. The "buttons" (10 to 79) will be associated then to the further address in sequence.

**I** A secondo della modalità selezionata l'associazione dell'indirizzo tasto di chiamata al "tasto" interno al dispositivo varia. La definizione "tasto" non si riferisce però ad un tasto fisico ma bensì alla locazione dove viene memorizzato il numero telefonico. Questa deve essere associata all'indirizzo che viene inviato dalla pulsantiera. Questi indirizzi vengono definiti nella pulsantiera stessa (a tale riguardo fare riferimento alla documentazione tecnica relativa). In modalità "Standard" l'indirizzo del tasto di chiamata (da 001 a 200) viene associato ai singoli tasti (da 1 a 4). In modalità "Estesa" viene solo programmato l'indirizzo del primo tasto (da 001 a 121). I "tasti" (da 10 a 79) vengono poi associati in sequenza.

Rufnummern ("Standard") / Telephone numbers ("Standard") / Numeri telefonici ("Standard")



8 8 8 2 8 1 - 4



5''



Taste  
Button  
Tasto

<NR/NO/NR>  
Telefonnummer (1 - 0, \*, #)  
Telephone number (1 - 0, \*, #)  
Numero telefonico (1 - 0, \*, #)

BIP  
BIP  
BIP

Rufnummern ("Erweitert") / Telephone numbers ("Expanded") / Numeri telefonici ("Estesa")

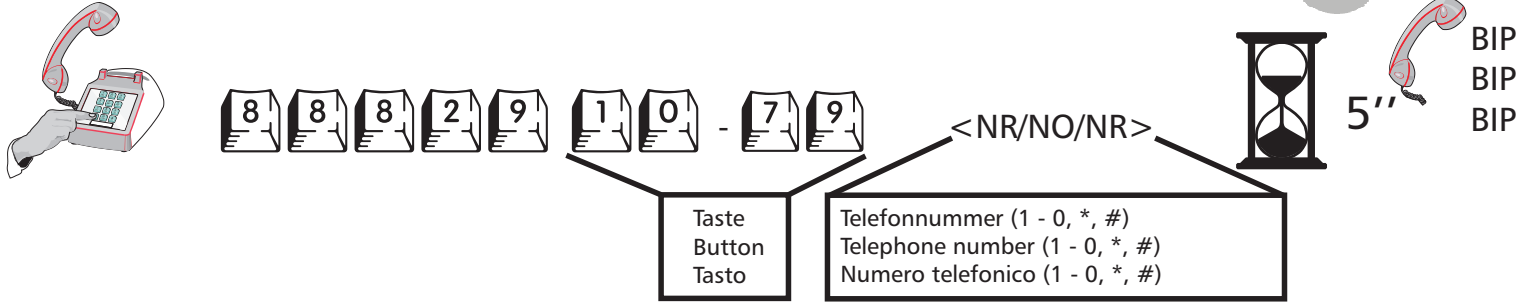

Wartezeit vor der Wahl / Waiting time before dial / Tempo attesa prima della selezione (Default: 1s)

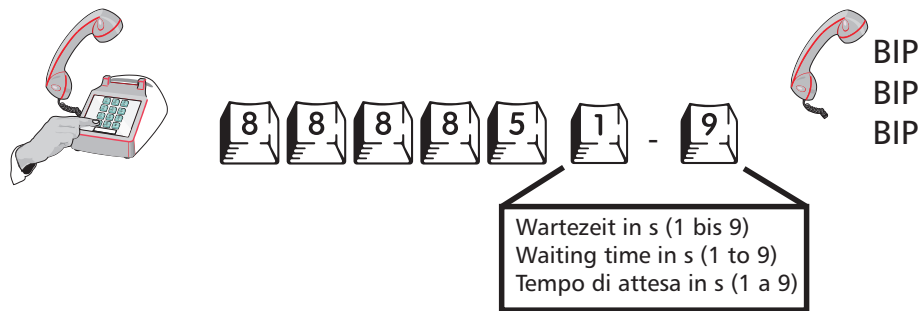

Verbindung nach Türöffnung automatisch trennen/ Automatic termination after door opening / Chiusura automatica dopo apertura porta

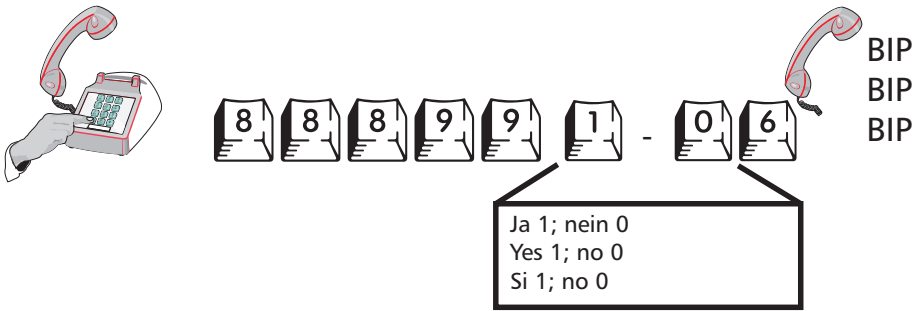

Bedienungsanleitung/user guide/guida all'uso

