

ML2002AGLE/2

myLogic<sub>one</sub>  
ML2002C

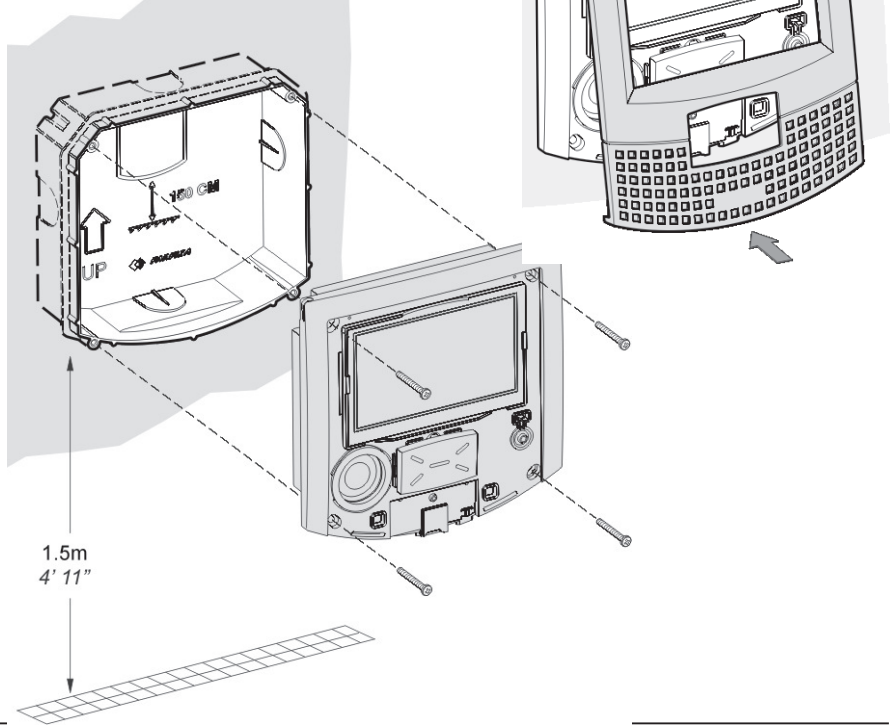

**AGORA**  
VD2102AGL

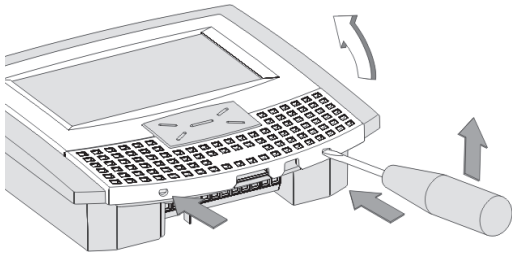
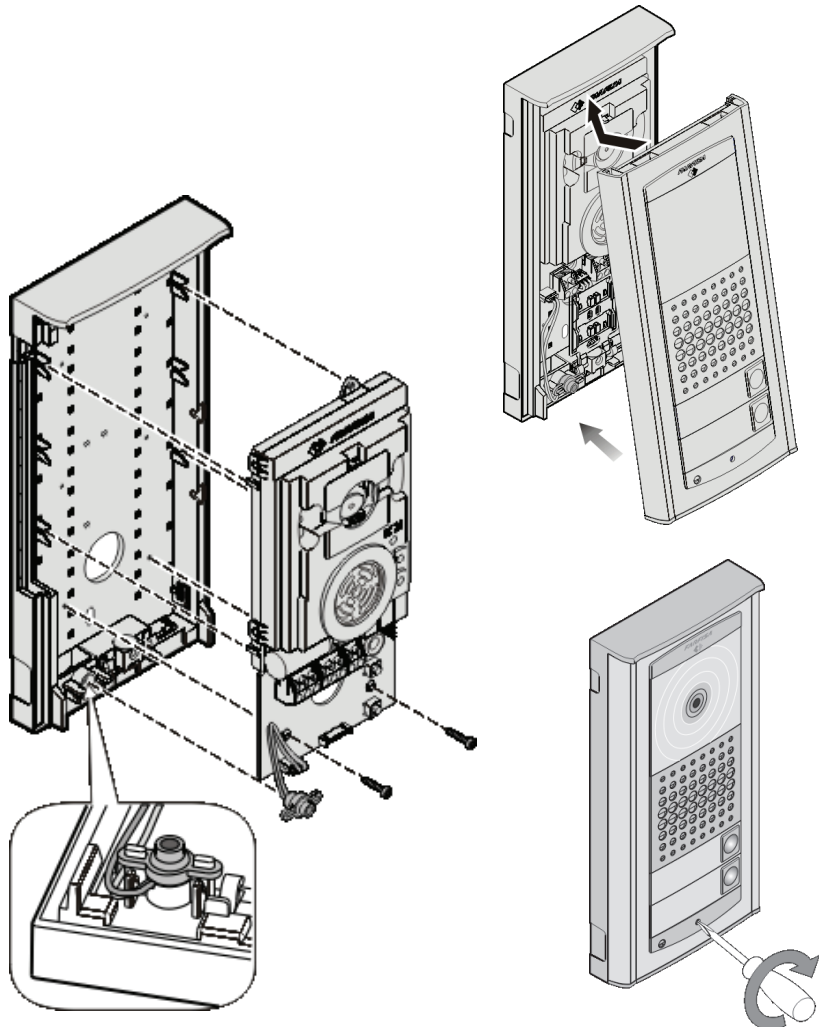
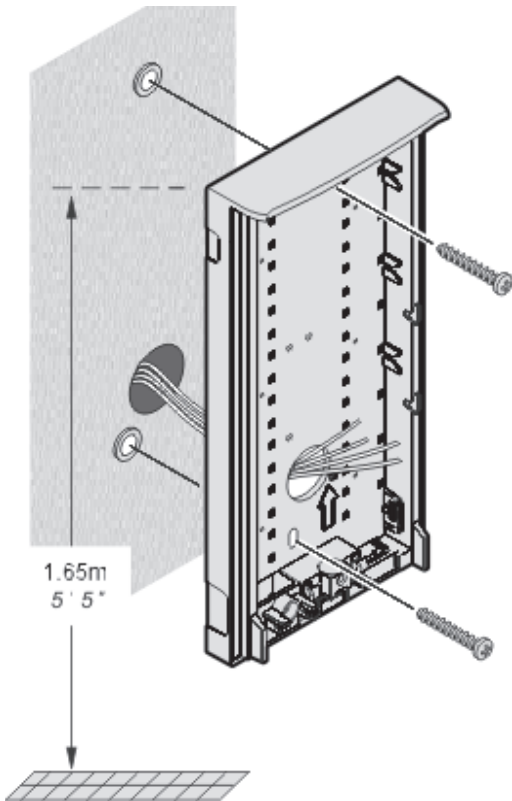

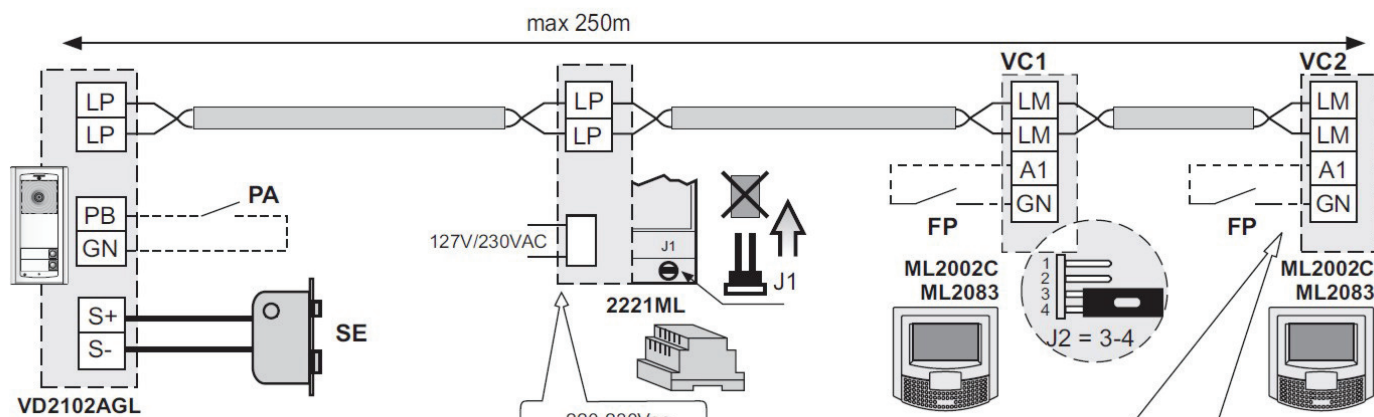

- PA** = Pulsante apriporta (opzionale)  
Door release push-button (optional)  
Bouton-poussoir ouvre porte (optionnel)  
Pulsador abrepuerta (opcional)  
Botão para abrir a porta (opcional)  
Türöffnertaste (Zusatztaste)
- SE** = Serratura elettrica (12Vca-1A max.)  
Electric door lock (12VAC-1A max)  
Gâche électrique (12Vca-1A max)  
Cerradura eléctrica (12Vca-1A máx.)  
Fechadura eléctrica (12Vca-1A max)  
elektrischer Türöffner (12VWs-1A max)
- FP** = Pulsante chiamata di piano (opzionale)  
Floor call push-button (optional)  
Bouton-poussoir de palier (optionnel)  
Pulsador de piso (opcional)  
Botão de patamar (opcional)  
Etagenruftaste (Zusatztaste)

- IT** Tabella delle distanze massime garantite  
**EN** Table of the maximum permitted distances  
**FR** Tableau des distances maximales garanties  
**ES** Tabla de las distancias máximas garantizadas  
**PT** Tabela das distâncias máximas garantidas  
**DE** Tabelle der garantierten maximale Kabellängen

Cavo Farfisa 2302 Farfisa 2302 cable Câble Farfisa 2302 Cable Farfisa 2302 Cabo Farfisa 2302 Farfisa 2302 Kabel 2x1mm <sup>2</sup> - AWG17	Cavo telefonico Twisted cable Câble torsadé Cable trenzado Cabo trançado verdrilltes Kabel 2x0,32mm <sup>2</sup> - AWG22	Cavo CAT5 CAT5 cable Câble CAT5 Cable CAT5 Cabo CAT5 Kabel CAT5 2x0,2mm <sup>2</sup> - AWG24
250 m - 820 ft	70 m - 230 ft	50 m - 164 ft



- Per ulteriori informazioni consultare il sito:
- For more information, visit:
- Pour plus d'informations, visitez:
- Para obtener más información, visite:
- Para obter mais informações, visite:
- Für weitere Informationen, besuchen Sie:

[www.mylogic.biz](http://www.mylogic.biz)

**ROCOM**

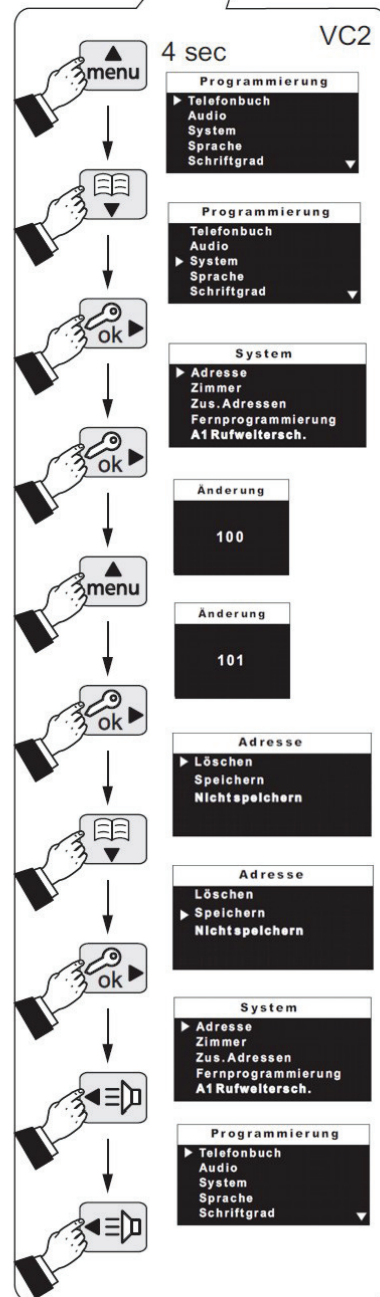

Smaltire il dispositivo secondo quanto prescritto dalle norme per la tutela dell'ambiente.  
Dispose of the device in accordance with environmental regulations.  
Écouler le dispositif selon tout ce qu'a été prescrit par les règles pour la tutelle du milieu.  
Eliminar el aparato según cuánto prescrito por las normas por la tutela del entorno.  
Disponha do dispositivo conforme regulamentos ambientais.  
Entsorgen Sie das Gerät in Übereinstimmung mit den gesetzlichen Vorgaben.

**Rocom Energie- und Kommunikationssysteme GmbH**  
Lessingstr. 20 • 63110 Rodgau • Deutschland  
Tel: +49 6106 66000 • Fax: +49 6106 66006  
e-mail: [info@rocom-gmbh.de](mailto:info@rocom-gmbh.de) • [www.rocom-gmbh.de](http://www.rocom-gmbh.de)

29-6937-1570